

MODEL 7705 STANDARD FLEXIBLE COUPLING

The Model 7705 Standard Flexible Coupling is a standard flexible coupling for use in a variety of general piping applications of moderate pressure services. The model 7705 couplings features flexibility that can deal with misalignment, distortion, thermal stress, vibration and noise and also resist seismic tremors. With the use of Model 7705 couplings you can even design a curved layout. See Typical Applications – Flexible Couplings on *Shurjoint* cut sheet #B-19.

All Model 7705 couplings are comprised of two identical ductile iron housings segments, EPDM rubber gasket and plated track bolts & nuts. Housings segments are supplied with our standard painted finishes, i.e. orange or RAL3000 red. Optional finishes such as hot dipped zinc galvanized and custom epoxy coatings are available.

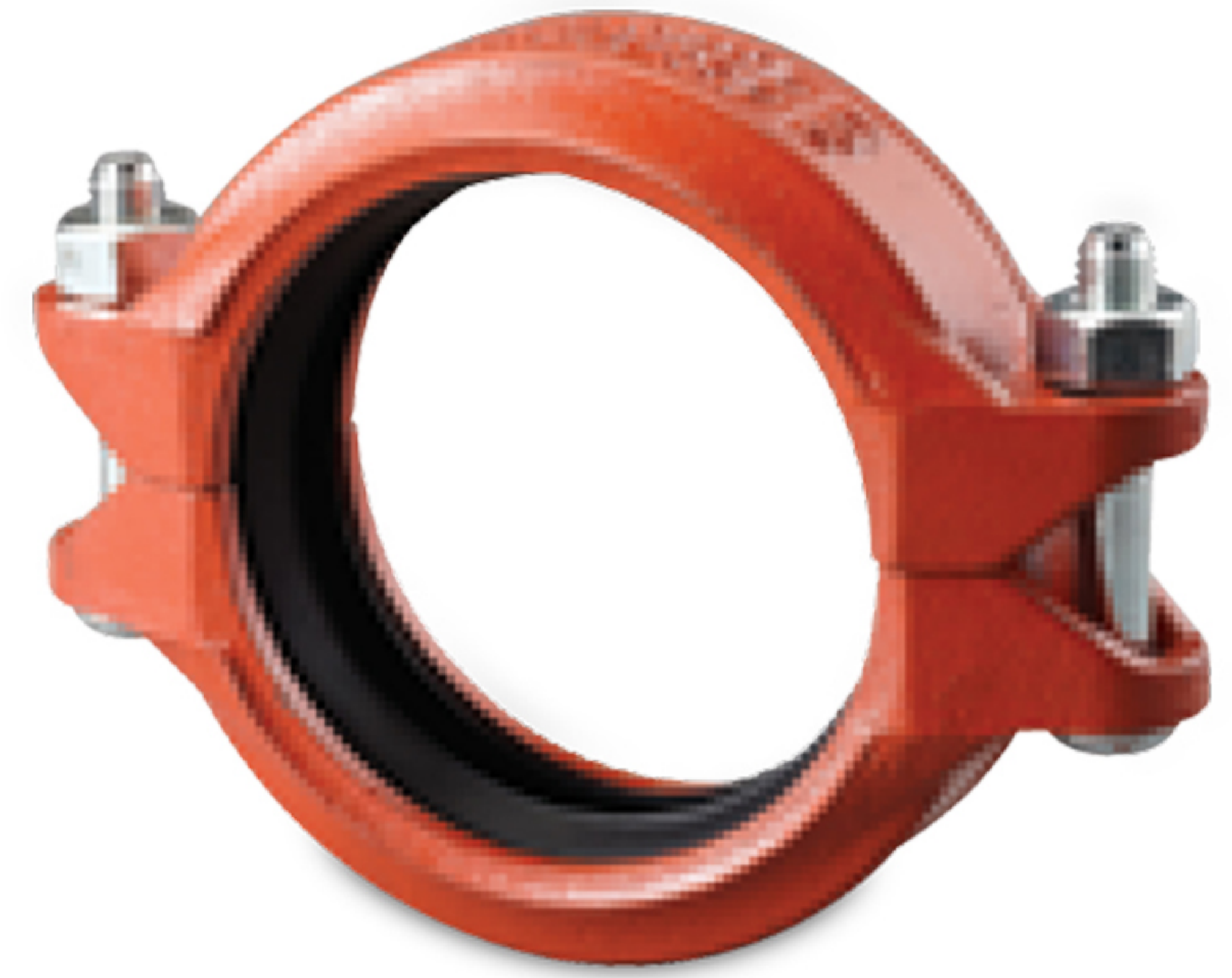

7705 couplings should always be installed so that the coupling bolt pads make metal to metal contact.

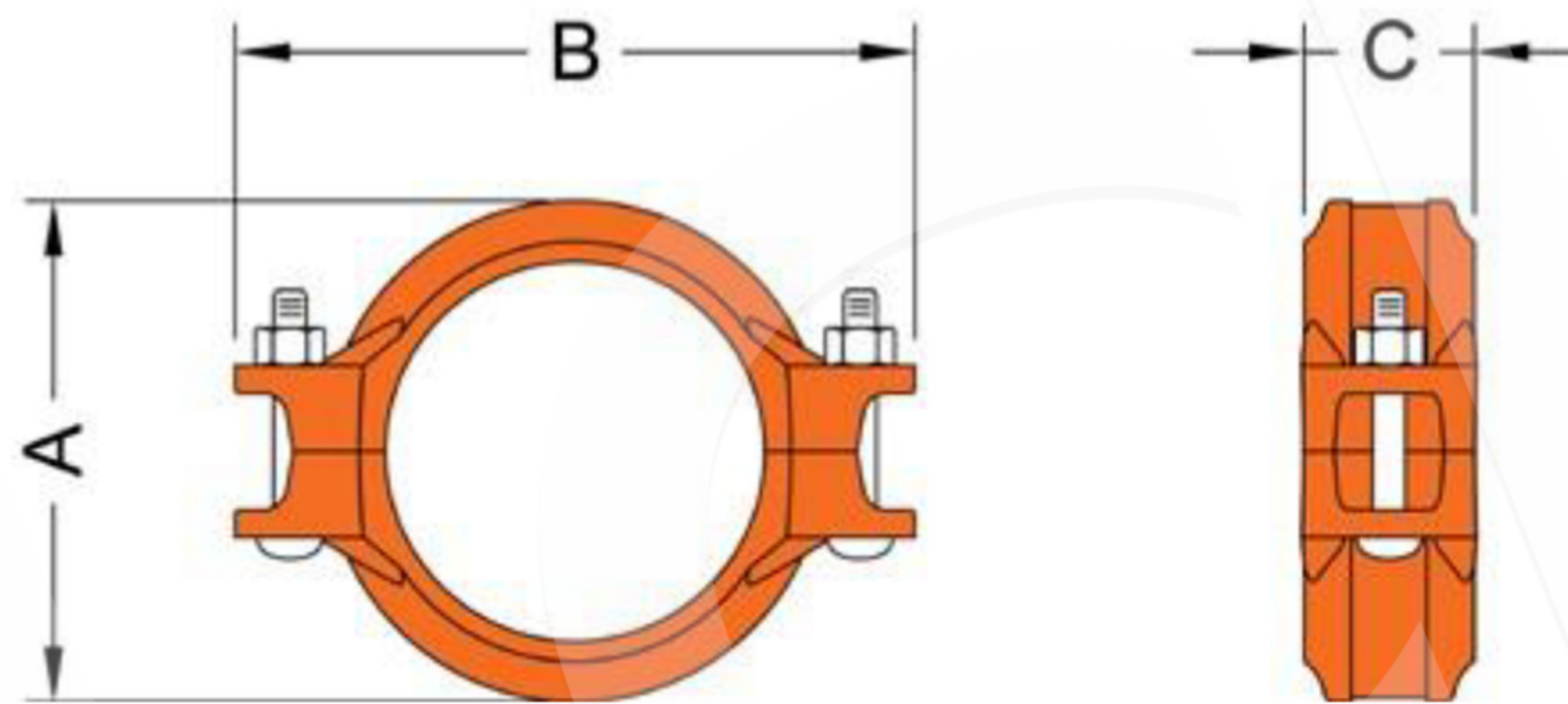

**10
YEAR
LIMITED
WARRANTY**

Full warranty terms can be found on www.shurjoint.com

Model 7705 Standard Flexible Coupling

Nominal Size	Pipe O.D.	Max. Working Pressure (CWP)*	Max. End Load (CWP)	Axial Displacement †	Angular Movement **†		Dimension:			Bolt Size	Weight
					Deg. Per Coupling	Per Pipe	A	B	C		
in	in	PSI	Lbs	in	(°)	in/ft	in	in	in	in	Lbs
mm	mm	Bar	kN	mm		mm/m	mm	mm	mm	mm	Kgs
1	1.315	500	670	0.0625	2° - 45'	0.58	2.24	3.94	1.81	3/8 x 1 3/4	1.3
25	33.4	35	3.12	1.6		48	57	100	46	M10 x 45	0.6
1 1/4	1.660	500	1080	0.0625	2° - 10'	0.46	2.60	4.06	1.81	3/8 x 2 1/8	1.5
32	42.2	35	4.94	1.6		38	66	103	46	M10 x 55	0.7
1 1/2	1.900	500	1410	0.0625	1° - 54'	0.4	2.83	4.25	1.81	3/8 x 2 1/8	1.6
40	48.3	35	6.41	1.6		33	72	108	46	M10 x 55	0.7
2	2.375	500	2210	0.0625	1° - 31'	0.32	3.31	5.08	1.85	3/8 x 2 1/8	1.8
50	60.3	35	9.99	1.6		27	84	129	47	M10 x 55	0.8
2 1/2	2.875	500	3240	0.0625	1° - 15'	0.26	3.90	5.59	1.85	3/8 x 2 1/8	2.0
65	73.0	35	14.64	1.6		22	99	142	47	M10 x 55	0.9
76.1 mm	3.000	500	3530	0.0625	1° - 12'	0.25	4.02	5.79	1.85	3/8 x 2 1/8	2.1
	76.1	35	15.91	1.6		21	102	147	47	M10 x 55	1.0
3	3.500	500	4800	0.0625	1° - 02'	0.22	4.57	6.46	2.05	1/2 x 3	2.8
80	88.9	35	21.71	1.6		18	116	164	52	M12 x 75	1.3
101.6 mm	4.000	500	6280	0.0625	0° - 54'	0.19	5.07	7.24	2.05	1/2 x 3	3.6
	101.6	35	28.36	1.6		16	129	184	52	M12 x 75	1.6
108.0 mm	4.250	500	7080	0.1250	1° - 42'	0.36	5.43	7.56	2.05	1/2 x 3	4.1
	108.0	35	32.05	3.2		30	138	192	52	M12 x 75	1.9
4	4.500	500	7940	0.1250	1° - 36'	0.34	5.71	7.76	2.05	1/2 x 3	4.1
100	114.3	35	35.89	3.2		28	145	197	52	M12 x 75	1.9
133.0 mm	5.250	450	9730	0.1250	1° - 23'	0.29	6.50	9.09	2.05	5/8 x 3 1/2	5.1
	133.0	31	43.05	3.2		24	165	231	52	M16 x 90	2.3
139.7 mm	5.500	450	10680	0.1250	1° - 18'	0.28	6.69	9.76	2.05	5/8 x 3 1/2	5.9
	139.7	31	47.49	3.2		23	170	248	52	M16 x 90	2.7
5	5.563	450	10930	0.1250	1° - 18'	0.27	6.77	9.17	2.05	5/8 x 3 1/2	5.9
125	141.3	31	48.59	3.2		23	172	233	52	M16 x 90	2.7

Model 7705 Standard Flexible Coupling

Nominal Size	Pipe O.D.	Max. Working Pressure (CWP)*	Max. End Load (CWP)	Axial Displacement †	Angular Movement **†		Dimensions			Bolt Size	Weight
					Deg. Per Coupling	Per Pipe	A	B	C		
					(°)	in/ft	in	in	in		
in mm	in mm	PSI Bar	Lbs kN	in mm	(°)	in/ft mm/m	in mm	in mm	in mm	in mm	Lbs Kgs
159.0 mm	6.250 159.0	450 31	13790 61.52	0.1250 3.2	1° - 09'	0.24 20	7.48 190	9.96 253	2.05 52	5/8 x 3 1/2 M16 x 90	6.6 3.0
165.1 mm	6.500 165.1	450 31	14920 66.33	0.1250 3.2	1° - 07'	0.24 20	7.72 196	10.28 261	2.09 53	5/8 x 3 1/2 M16 x 90	6.8 3.1
6 150	6.625 168.3	450 31	15500 68.93	0.1250 3.2	1° - 05'	0.23 19	7.87 200	10.55 268	2.09 53	5/8 x 3 1/2 M16 x 90	7.0 3.2
8 200	8.625 219.1	300 20	17510 75.37	0.1250 3.2	0° - 50'	0.18 15	10.24 260	13.27 337	2.44 62	5/8 x 3 1/2 M16 x 90	12.8 5.8
8 (7705H) 200	8.625 219.1	450 31	26270 116.82	0.1250 3.2	0° - 50'	0.18 15	10.47 266	13.07 332	2.44 62	3/4 x 4 3/4 M20 x 120	15.7 7.1
10 250	10.750 273.0	300 20	27210 117.01	0.1250 3.2	0° - 40'	0.14 12	13.50 343	13.78 350	2.56 65	3/4 x 4 3/4 M20 x 120	18.0 8.2
12 300	12.750 323.9	300 20	38280 164.71	0.1250 3.2	0° - 34'	0.12 10	15.35 390	15.75 400	2.56 65	7/8 x 6 1/2 ---	23.8 10.8
200 JIS	8.516 216.3	300 20	17079 73.45	0.1250 3.2	0° - 51'	0.18 15	10.00 254	13.70 348	2.36 60	3/4 x 4 3/4 M20 x 120	12.8 5.8
250 JIS	10.528 267.4	300 20	26103 112.26	0.1250 3.2	0° - 41'	0.15 12	13.27 337	15.28 388	2.56 65	3/4 x 4 3/4 M20 x 120	17.6 8.0
300 JIS	12.539 318.5	300 20	37027 159.26	0.1250 3.2	0° - 35'	0.12 10	15.31 389	17.48 444	2.56 65	7/8 x 6 1/2 ---	22.6 10.3

All DIN size 7705 couplings up to DN150 size and the DN200 7705H coupling are VdS approved in addition to cULus and FM approvals.

* Working Pressure is based on roll grooved standard wall carbon steel pipe.

† Allowable Axial Displacement and Angular Movement (deflection) figures are for roll grooved standard steel pipe. Values for cut grooved pipe will be double that of roll grooved. These values are maximums; for design and installation purposes these figures should be reduced by: 50% for 3/4"/DN20 – 3 1/2"/DN90; 25% for 4"/DN100 and larger to compensate for jobsite conditions.

** Deflection or angular movement given is the maximum value that a coupling allows. When using the given maximum angles for a curved layout, proper bracing should be used to counter pressure thrust that will occur when the system is pressurized.

Flexible couplings can be used for angular movement and or thermal expansion, though please note individual coupling(s) cannot be used to their maximums for both types of movement within a system at the same time.

Performance Data

The following tables show the maximum working pressures (CWP) of **Shurjoint** Model 7705 Flexible Coupling used on both carbon steel and stainless steel pipes. **Shurjoint** ductile iron couplings can be used in conjunction with stainless steel pipe in non-corrosive environment as the flow media does not come in direct contact with the coupling housings but rather only the gasket.

Model 7705 on Carbon Steel Pipe					
Nom. Size	Cut-Grooved		Roll-Grooved		
in / mm	XS PSI / Bar	STD PSI / Bar	STD PSI / Bar	Sch. 10 PSI / Bar	Sch. 7 PSI / Bar
1	600	600	500	400	300
25	42	42	35	28	20
1 1/4	600	600	500	400	300
32	42	42	35	28	20
1 1/2	600	600	500	400	300
40	42	42	35	28	20
2	600	600	500	400	300
50	42	42	35	28	20
2 1/2	600	600	500	400	300
65	42	42	35	28	20
3	600	600	500	400	300
80	42	42	35	28	20
4	600	600	500	400	300
100	42	42	35	28	20
5	450	450	450	350	250
125	31	31	31	24	17
6	450	450	450	350	250
150	31	31	31	24	17
8	450	450	300	250	200
200	31	31	20	17	14
10	350	350	300	200	175
250	24	24	20	14	12
12	350	350	300	200	175
300	24	24	20	14	12

Model 7705 on Stainless Steel Pipe					
Nom. Size	Cut-Grooved		Roll-Grooved		
in / mm	Sch. 80S PSI / Bar	Sch. 40S PSI / Bar	Sch. 40S PSI / Bar	Sch. 10S PSI / Bar	Sch. 5S PSI / Bar
1	600	600	450	300	250
25	42	42	31	20	17
1 1/4	600	600	450	300	250
32	42	42	31	20	17
1 1/2	600	600	450	300	250
40	42	42	31	20	17
2	600	600	450	300	250
50	42	42	31	20	17
2 1/2	600	600	450	300	250
65	42	42	31	20	17
3	600	600	450	300	250
80	42	42	31	20	17
4	600	600	450	300	200
100	42	42	31	20	14
5	450	450	300	200	NR
125	31	31	20	14	NR
6	450	450	300	125	NR
150	31	31	20	9	NR
8	450	450	300	100	NR
200	31	31	20	7	NR
10	350	350	200	NR	NR
250	24	24	14	NR	NR
12	350	350	200	NR	NR
300	24	24	14	NR	NR

MATERIAL SPECIFICATIONS

- **Housing:**

Ductile Iron to ASTM A536, Gr. 65-45-12 and or ASTM A395, Gr. 65-45-15, min. tensile strength 65,000 psi (448 MPa).

- **Surface Finish:**

Standard painted finishes in orange or RAL3000 red.

- Hot dip zinc galvanized (Option).
- Epoxy Coatings in RAL3000 red or other colors (Option)

- **Rubber Gasket:**

Grade E-pw EPDM (Color code: Double Green stripe) approved under NSF/ANSI 61 and NSF/ANSI 372 for potable water service to +180°F (+82°C). Also good for services for water with acid, water with chlorine, deionized water, seawater and waste water, dilute acids, oil-free air and many chemicals.

Not recommended for petroleum oils, minerals oils, solvents and aromatic hydrocarbons.

Maximum Temperature Range: -30°F (-34°C) to +230°F (+110°C)*.

*EPDM seat for water services are not recommended for steam services unless valves or components are accessible for frequent replacement.

- (Option) **Grade “E” EPDM** (Color code: Green stripe) Good for cold & hot water up to +230°F (+110°C). Also good for services for water with acid, water with chlorine or chloramines, deionized water, seawater and waste water, dilute acids, oil-free air and many chemicals. **Not recommended for petroleum oils, minerals oils, solvents and aromatic hydrocarbons.**

Maximum Temperature Range: -30°F (-34°C) to +230°F (+110°C)*.

*EPDM seat for water services are not recommended for steam services unless valves or components are accessible for frequent replacement.

- (Option) **Grade “T” Nitrile** (Color code: Orange stripe) Recommended for petroleum products, air with oil vapors, vegetable and mineral oils within the specified temperature range. Also good for water services under +150°F (+66°C). Temperature range: -20°F to +180°F (-29°C to +82°C). **Do not use for HOT WATER above +150°F (+66°C) or HOT DRY AIR above +140°F (+60°C).**
- Other options: Grade “O” - Fluoroelastomer. Grade “L” - Silicone. For additional details contact **Shurjoint**.

- **Bolts & Nuts:**

Heat treated carbon manganese steel track bolts to ASTM A449-83a (or A183 Gr. 2), minimum tensile strength 110,000 psi (758 MPa), Zinc electroplated, with heavy-duty hexagonal nuts to ASTM A563.

LISTINGS / APPROVALS

The information provided below is based on the latest listing and approval data at the time of publication. Listings/Approvals are subject to change and/or additions by the approvals agencies. Contact **Shurjoint** for the performance on other pipes and the latest listings and approvals

Standard Pipe

Nom. Size	cULus Sch. 5	cULus/FM Sch. 10/40	VdS	LPCB	Nom. Size	cULus/FM Sch. 10/40	VdS	LPCB	Nom. Size	cULus/FM Sch. 10/40	VdS	LPCB
in / mm	psi / Bar	psi / Bar	Bar	psi / Bar	in / mm	psi / Bar	Bar	psi / Bar	in / mm	psi / Bar	bar	psi / Bar
1 25	-	300 20	16	-	4 100	300 20	16	300 20	8 (7705H) 200	450 31	16	-
1¼ 32	175 12	300 20	16	-	133.0 mm	-	16	-	10 250	175 12	-	-
1½ 40	175 12	300 20	16	-	139.7 mm	300 20	16	300 20	12 300	-	-	-
2 50	175 12	300 20	16	300 20	5 125	300 20	-	-	-	-	-	-
2½ 65	175 12	300 20	-	-	159.0 mm	-	16	-	-	-	-	-
76.1 mm	-	300 20	16	300 20	165.1 mm	300 20	-	300 20	-	-	-	-
3 80	175 12	300 20	16	300 20	6 150	300 20	16	-	-	-	-	-
108.0 mm	-	-	16	-	8 200	300 20	-	300 20	-	-	-	-

* For listings and approval information and ratings on non-standard pipe please refer to the actual listings and or approval information found on our web site or contact **Shurjoint** for assistance.

General Notes:

- **Maximum Working Pressure (CWP)** listed is the maximum cold water pressure for general piping services tested to ASTM F1476 and or AWWA C606 methods. Figures listed are based on roll- or cut-grooved standard wall carbon steel pipe. For other pipe schedules or pipe materials, contact **Shurjoint** for additional information.
- **Max. End Load** is calculated based on the maximum working pressure (CWP).
- **Listed and or Approved Pressures** are pressure ratings for fire protection systems, tested and approved by various approval bodies. Please always refer to the latest approval data posted on the **Shurjoint** website.
- **Field Joint Test:** For one time only the system may be tested hydrostatically at 1½ times the maximum working pressure listed (AWWA C606 5.2.3).
- **Warning:** Piping systems must always be depressurized and drained before attempting disassembly and or removal of any components.
- **The 10 Year Limited Warranty** applies to manufacturing defects only and does not cover severe service/temperature applications or wear parts.
- **Shurjoint** reserves the right to change specifications, designs and or standard without notice and without incurring any obligations.

Shurjoint product specifications in U.S. customary units and metric are approximate and are provided for reference only. For precise measurements, please contact **Shurjoint** Technical Service. **Shurjoint** reserves the right to change or modify product design, construction, specifications, or materials without prior notice and without incurring any obligations to make such changes and modifications on **Shurjoint** products previously subsequently sold.